

HPSAW 310 Band Saw Machine

Fully automatic high-speed saw for steel



HPSAW 310

High-speed saw for steel

Completely new development for maximum performance and efficiency.



HYPERSAW TECHNOLOGY

The all new HPSAW 310 Hypersaw redefines the performance limits of band sawing technology.

The most experienced AMADA development engineers have combined their ability and knowledge into this superior machine tool system. Depending on the type of steel, there is a three to four-fold improvement in cutting performance compared to circular saws equipped with carbide saw blades and when compared to conventional band saws with bimetal saw blades, it is possible to increase the cutting performance ten-fold.

The HPSAW 310 is built around a stable bridge frame which means that the saw frame does not distort even at high loads. To prevent harmful loads on the tool, extensive measures were taken to prevent vibration.

Double rollers on both sides ensure smooth running of the saw and the high-pressure cooling system provides a dampening fluid cushion for the newly developed saw blade guides. The completely new patented system reduces saw blade friction which means that considerably less energy is consumed.

The AXCELA HP1 coated carbide saw blade that was developed together with the HPSAW 310 was optimized for longer service life with extreme performance values and the costs per cut were effectively reduced by half.*

* Compared to a conventional band saw with uncoated carbide saw blades

DETAILS



Tidy work space for optimum chip management

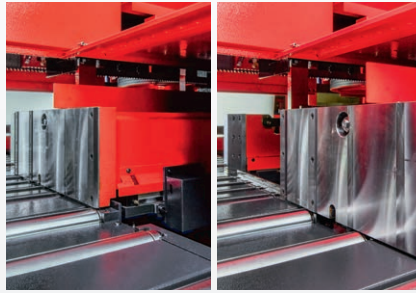

Robust vice system

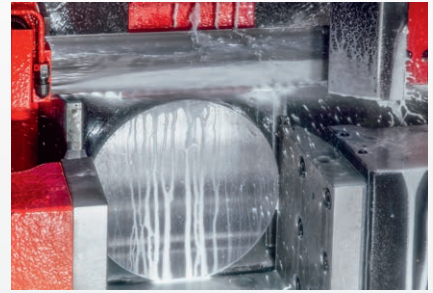

High-pressure cooling system (3.95 MPa)

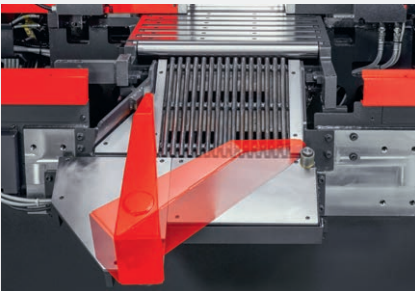

Automatic leftover switch



AXCELA HP1
Coated carbide saw blade for maximum performance on the HPSAW 310

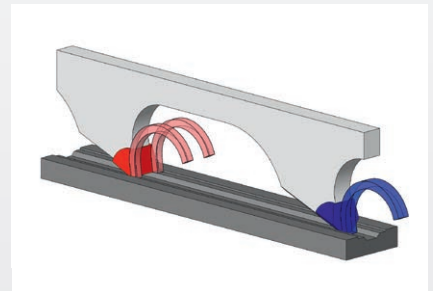

AXCELA HP1
Optimized tooth group design

FURTHER ADVANTAGES

- Fully encapsulated housing
- FEM optimized frame structure
- High-pressure cooling system (AFCS) for optimum cooling and chip removal
- Double-sided oblique-cut monitoring
- Feed system servo drive (12m/min)
- 60% less chips compared to a circular saw with the same cutting width
- AMADA antivibration technology
- User-friendly control
- Energy and resource-saving operation
- Prepared for expansion with automatic feed and removal system

EFFICIENCY

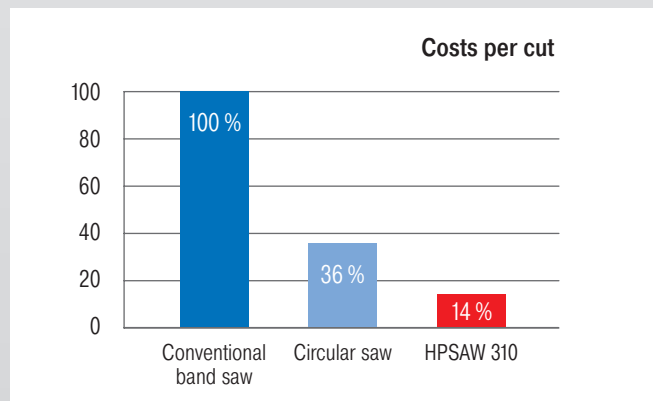
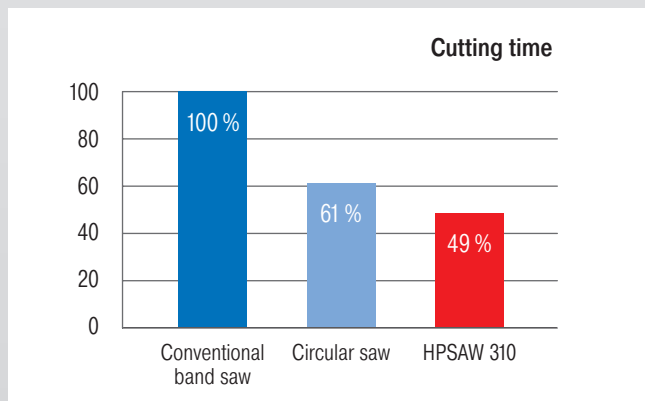

Thanks to its extremely high performance, a single HPSAW 310 can replace several band and circular saws. In addition to the machine-related advantages, this also results in considerable economic potential due to lower space, maintenance, energy and staff requirements. Amortisation is reached in a very short time in the case of corresponding sawing tasks.

TECHNICAL DATA

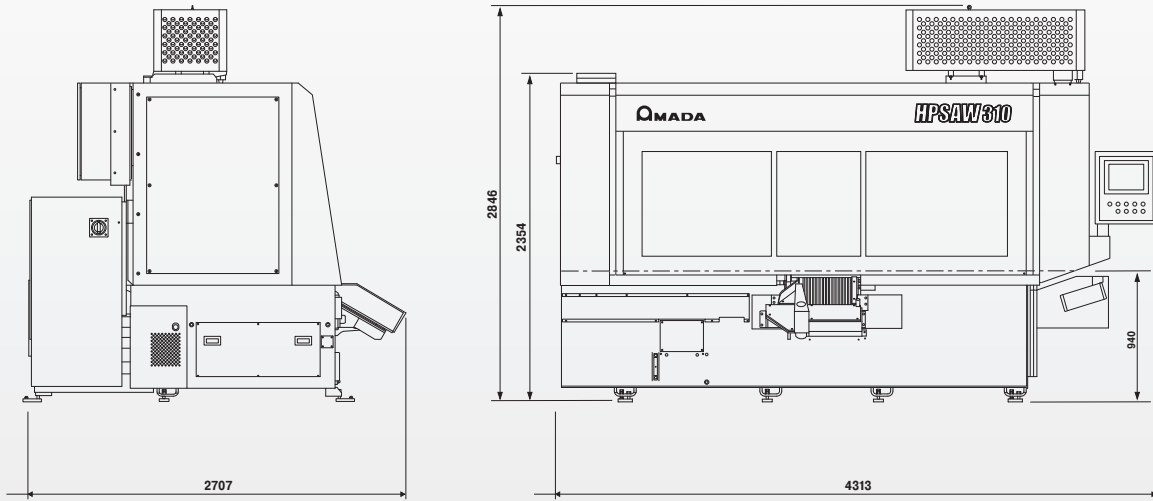

HPSAW 310 Technical Data		
Sawing capacity	Round material square material	○ 50 mm ~ ○ 310 mm □ 50 mm ~ □ 310 mm
Motor power	Saw band drive hydraulic pump	22 kW x 4P 3.7 kW x 4P
Saw blade dimension	(H x W x L)	67 x 1.6 x 7.345 mm (AXCELA HP1)
Blade speed		15-400 m/min continuously variable
Vice	Hydr. cylinder positioning	Triple shared vice zero stop (standard)
High-pressure cooling system		3.95 MPa
Material feed	Type Feed length Cut-off length min. residual length	Feed vice servo drive per stroke 600 mm 10 mm - 600 mm 50 mm in automatic operation
CNC controller		automatic parameter setting
Table height		940 mm
Material loading weight		1,100 kg
Machine dimensions	W x D x H	4,313 x 2,707 x 2,354 mm
Machine weight		8,000 kg

Subject to technical modifications / Illustrations partially with special accessories

AUTOMATION

The use of proven AMADA automation solutions material feed and removal is recommended for optimum efficiency. The portfolio comprises various loading magazines, automatic storage systems, sorting lines, palleting systems etc. Let the AMADA project team advise you.



AMADA MACHINE TOOLS EUROPE

AMADA MACHINE TOOLS EUROPE GmbH

Amada Allee 3, 42781 Haan, Germany

Tel.: +49 (0) 2104 177 70, Mail: info@amadamachinetools.de, www.amadamachinetools.de



740000181